

Solutions

ECE 462 Logic Design (Spring 2005)

Name: _____

Total Points: 25

This test is worth 23% of the final grade.

Duration: 50 minutes

You may bring 2 double-sided sheet of handwritten notes to this test.

If you need to make additional assumptions to answer a question, please state your assumptions clearly.

1. (4 points) Consider the circuit below. Using the Boolean difference method, find all tests for h stuck-at-0 and h stuck-at-1 faults. If such tests do not exist, state so. (Note that h is the output of the OR gate labelled as A in the figure.)

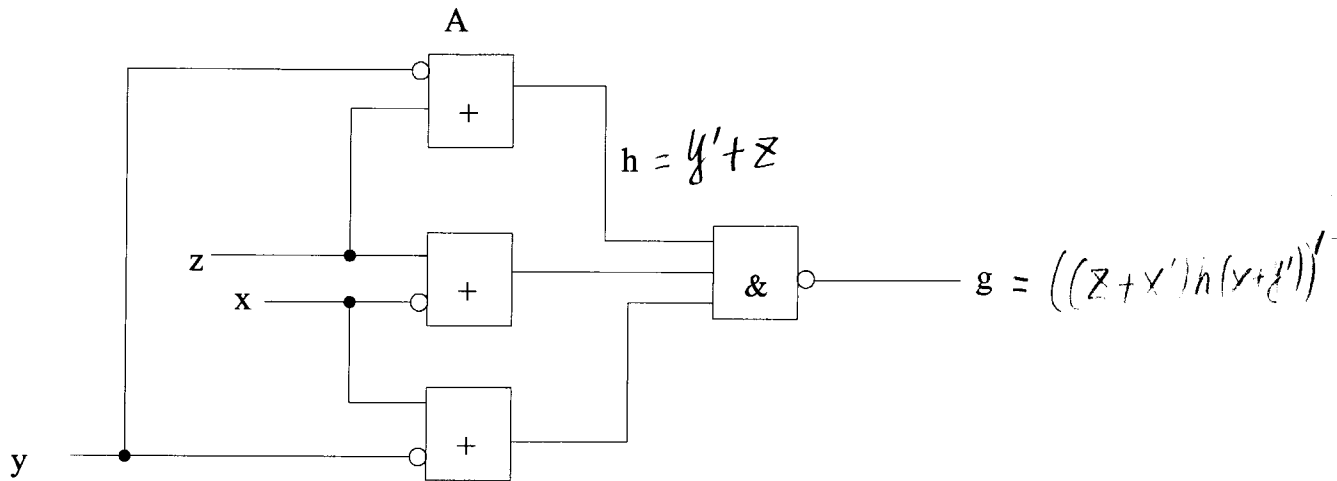

$$g_h = [(z+x')(x+y')] \quad g_{h'} = 1$$

$$\begin{aligned} \frac{dg}{dh} &= [(z+x')(x+y')] \oplus 1 = (x'+z)(x+y') \\ &= xx' + zx + x'y' + y'z = xz + x'y' + \overset{\text{consensus}}{y'z} = xz + x'y' \end{aligned}$$

Test h stuck-at-0:

$$h \frac{dg}{dh} = (y'+z)(xz + x'y') = xy'z + xz + x'y' + x'y'z = xz + x'y' = 1$$

$$\Rightarrow \text{Tests} = \{ \langle 101 \rangle, \langle 111 \rangle, \langle 000 \rangle, \langle 001 \rangle \}$$

$\langle x, y, z \rangle$

Test h stuck-at-1:

$$\begin{aligned} h' \frac{dg}{dh} &= (y'+z)'(xz + x'y') = yz'(xz + x'y') \\ &= \overset{0}{xyzz'} + \overset{0}{x'y'yz'} = 0 \neq 1 \Rightarrow \text{no test exists} \end{aligned}$$

2. (4 points) Figure below shows a circuit implementing function $f(w,x,y)$.

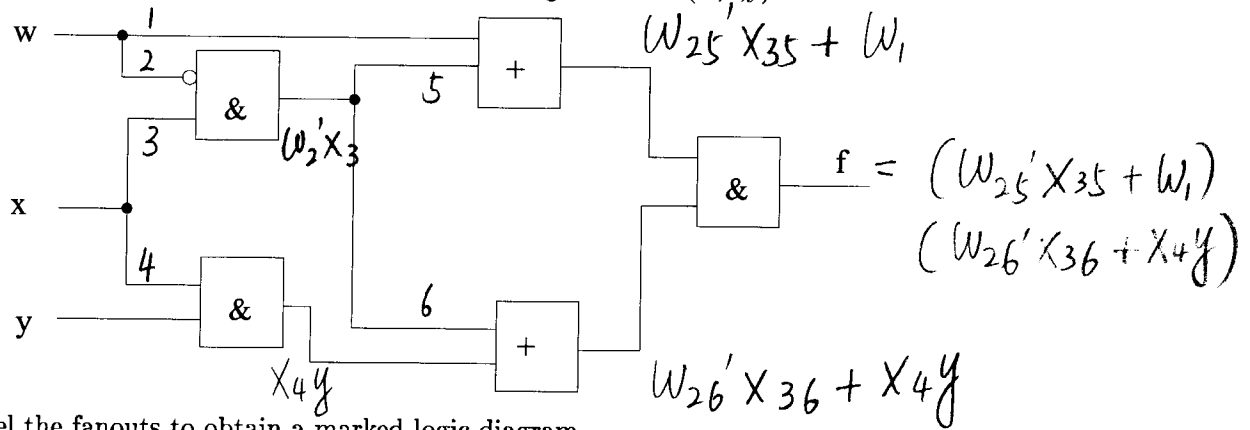

- Label the fanouts to obtain a marked logic diagram.
- Determine all the stable and unstable P-sets, if any exist.
- Identify any one dynamic hazard, if such a hazard exists.

(a) Labels as shown in the diagram above

(b) $f = (W_{25}'X_{35} + W_1)(W_{26}'X_{36} + X_4y)$

(Let $W_{25}' = W_7'$, $X_{35} = X_9$, $W_{26}' = W_8'$, $X_{36} = X_{10}$)

$$= (W_7'X_9 + W_1)(W_8'X_{10} + X_4y)$$

$$= W_7'X_9W_8'X_{10} + W_1W_8'X_{10} + W_7'X_9X_4y + W_1X_4y$$

Stable P-sets: $[W_7'X_9W_8'X_{10}]$, $[W_7'X_9X_4y]$, $[W_1X_4y]$

Unstable P-sets: $[W_1W_8'X_{10}]$

(c) $U = [W_1W_8'X_{10}]$

Let $B = [W_7'X_9X_4y] \Rightarrow X=1, y=1 \Rightarrow [W_1X_4y]$ is active
 \Rightarrow not a suitable B

Let $B = [W_7'X_9W_8'X_{10}] \Rightarrow X=1, y=0$ all other P-sets are nonactive

Hence $\langle w,x,y \rangle = \langle 110 \rangle \leftrightarrow \langle 010 \rangle$ is a dynamic hazard.

3. (4 points) Consider functions $f(w,x,y)$ and $g(w,x,y)$ whose Karnaugh maps are shown below.

		xy			
	w	00	01	11	10
0		1	1	1	0
1		0	0	1	0

$f(w,x,y)$

		xy			
	w	00	01	11	10
0		0	0	1	d
1		0	1	1	d

$g(w,x,y)$

Obtain a hazard-free minimal cost implementation for the multiple output circuit with outputs $f(w,x,y)$ and $g(w,x,y)$.

(If necessary, you may determine the multiple-output prime implicants using the Karnaugh maps, or any other method of your choice.)

fg

		xy			
	w	00	01	11	10
0		0	0	1	0
1		0	0	1	0

MOPI's: $\frac{xy}{f, g, fg}$, $\frac{w'x'}{f}$, $\frac{w'y}{f}$, $\frac{wy}{g}$, x

		f			g			fg		
		(0)	(1)	(3)	(5)	(3)	(2)	(2)	(6)	(3)
		(1)	(3)	(7)	(7)	(7)	(3)	(6)	(7)	(7)
		X			X					X

- * (3,7) xy
- (0,1) w'x' X
- (1,3) w'y X
- (5,7) wy
- (2,3,6,7) X

$f = xy + w'x' + w'y$

$g = xy + wy$ or $x + wy$

same cost

* if choose $d=0$, these pairs do not show up in the table

5. (3.5 points) Consider the transmission table shown below for a circuit with internal state variables y_1 and y_2 , and inputs w and x .

(a) Circle all stable states.

(b) Identify all races (mark them with #)

(c) Identify all critical races (mark them with *). Show your work to determine the critical races.

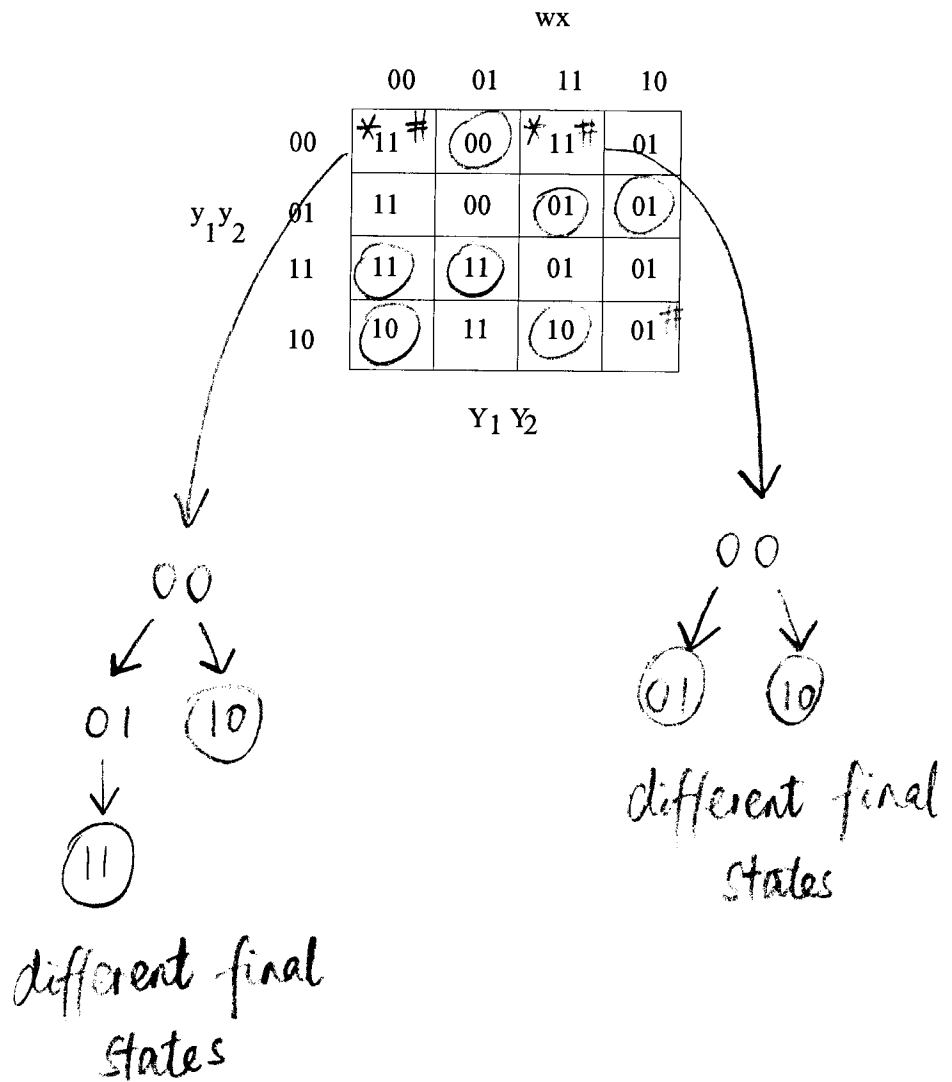

6. (3 points) The machine shown below has a single bit input x . Determine the equivalence classes for the states of this machine.

Determine Reduced Machine.

	x	
	0	1
A	D 0	C 1
B	A 0	D 1
C	F 0	A 0
D	E 0	C 1
E	A 0	G 1
F	E 0	A 1
G	B 0	E 0

Based on outputs,

$[A, B, D, E, F], [C, G]_2$
 12 11 12 12 11 11 11

$\Rightarrow [A, D, E], [B, F]_2 [C, G]_3$
 13 13 13 11 11 21 21

so $A \sim D \sim E$, $B \sim F$, $C \sim G$
 ① ② ③

Reduced machine

	x	
	0	1
1	1, 0	3, 1
2	1, 0	1, 1
3	2, 0	1, 0

7. (3 points) Determine reduced BDD for the function $f(w, x, y) = w'xy' + wy$ using the ordering $w < x < y$.

w	x	y	f
0	0	0	0
0	0	1	0
0	1	0	1
0	1	1	0
1	0	0	0
1	0	1	1
1	1	0	0
1	1	1	1

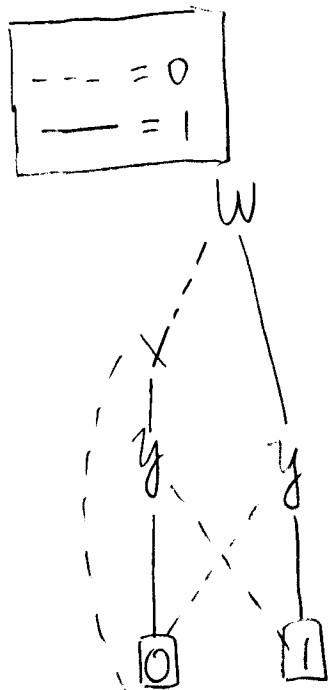
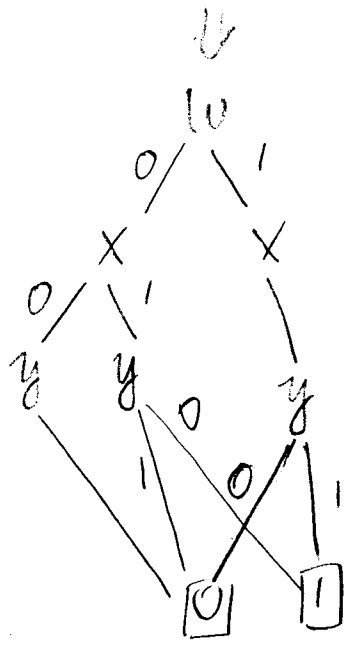
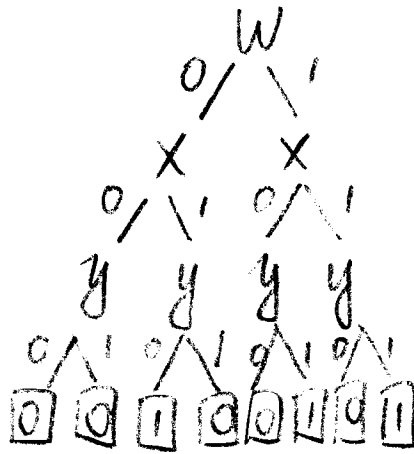

OR

